

solarspan[®] **insulroof[®]**
by BONDOR by BONDOR

DIY Freestanding Patio

Suitable for 4 post designs up to 6m x 5m

BONDOR[®]

Leaders in Thermal & Architectural Building Solutions

Install Guide

v0 2022

Disclaimer: This DIY Freestanding Patio Install Guide has been provided for generic SolarSpan[®] & InsulRoof[®] patio structures only which is based on the structural capacity determined through physical testing in accordance with the relevant Australian Standards. Other products will perform differently due to differences in steel and core material selection, manufacturing methods and testing.

The design and construction must be compliant with the Australian National Construction Code (NCC) and other applicable regulations and standards. The user is responsible that the details in this specification are appropriate for the intended application and that additional detailing is performed for specific design requirements or any areas that fall outside the scope of this specification.

Mark Out Post Locations & Prepare Footings

1. Posts should be located 100mm to 300mm in from the side of the patio roof line (side overhang)
2. Posts should be located 100mm to 600mm in from the front & rear of the patio roof line (end overhang)
3. Measure the diagonal distance between posts. Distance "A" should be equal to Distance "B"

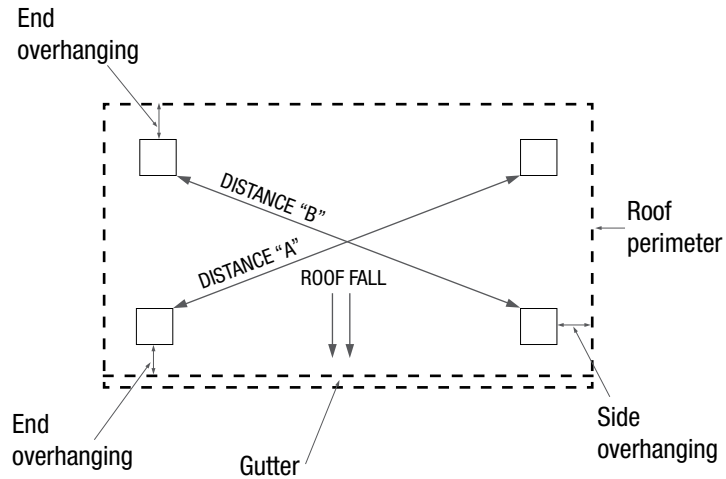

In Ground Footing – Aluminium / Steel Column

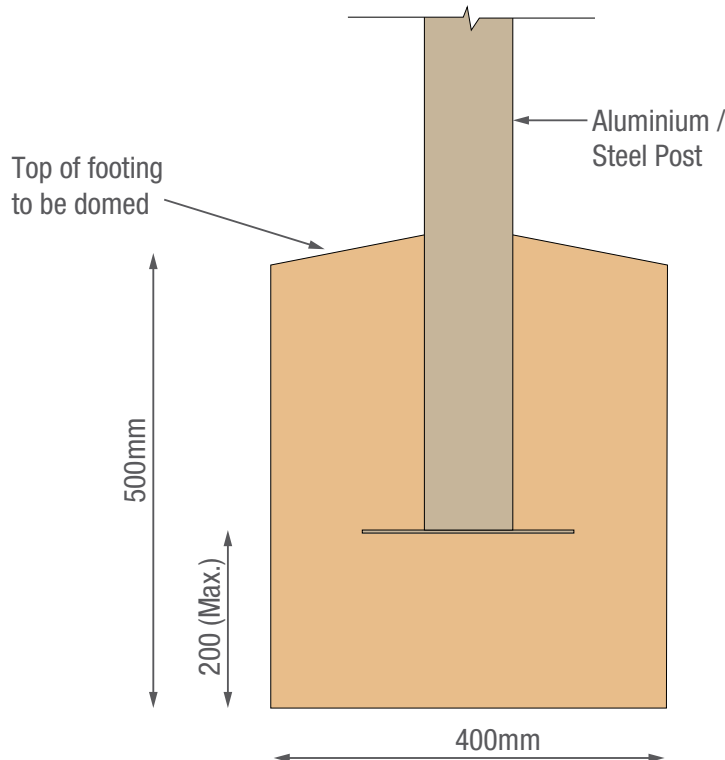

Note:
Footing dimensions are subject to soil type and wind loading.

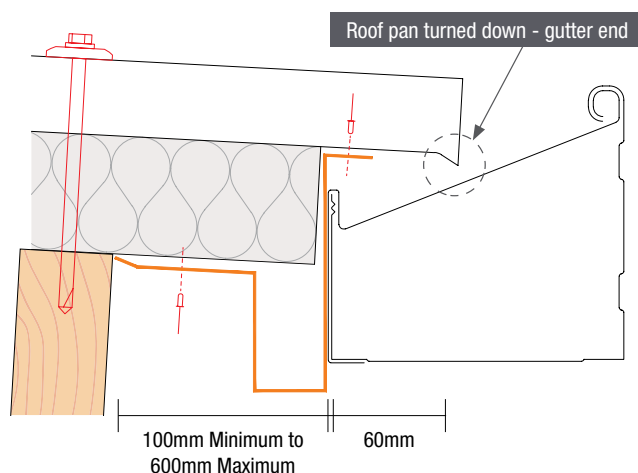

Cut Posts to Desired Length (Patio Height)

Post lengths can be prepared prior to concreting into the concrete footings.

Care should be taken to ensure a minimum 2-degree roof fall for SolarSpan[®] and a minimum 5-degree roof fall for InsulRoof[®].

Attaching the Fascia Beams

Using a spirit level double check all posts are standing straight.

Once the concrete footings have set (usually 24 hours) the front & rear fascia beams can be installed between the posts.

Using the supplied tek screws attach the beam brackets to the top of the posts.

Cut beams to the desired length (distance between the posts less 5mm for ease of fitting)

Place the beam into the beam brackets ensuring it is seated fully into the bracket.

Secure the beam into the beam bracket with the supplied tek screws.

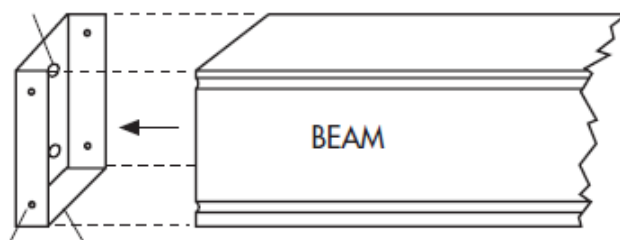

Prepare Roof Sheets

This example shows a typical freestanding patio installation. For other examples, visit www.solarspan.com.au. SolarSpan[®] is shown in the illustrations below but the instructions apply to InsulRoof[®] as well.

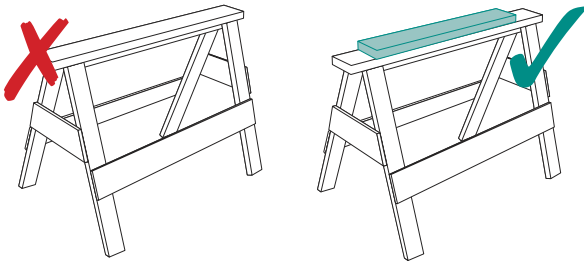

Handy Tip

Prepare your carpenter's trestles (or similar work platform) by taping soft material or foam to the top of the trestles.

Step 1: Panel Preparation

Place SolarSpan[®]/InsulRoof[®] panel roof side up on the trestles (avoid dragging the panel to eliminate damage).

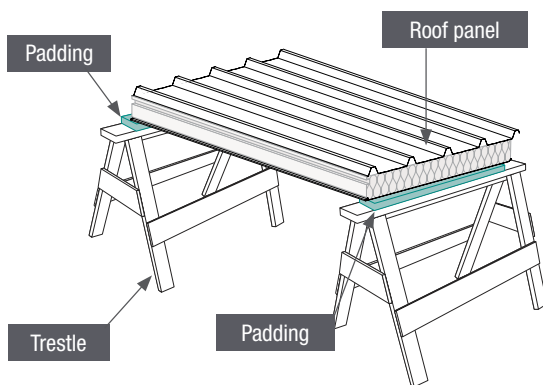

Step 2: Trim Overlap & Bend 90°

FIRST PANEL ONLY. The first overlay rib on the first panel acts as waterproofing under the side barge and should be trimmed using shears and bent up 90° as shown below.

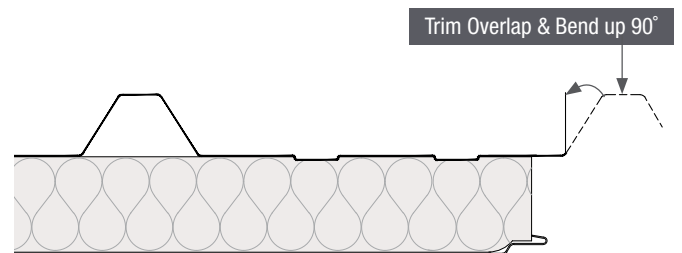

Step 3: Remove Foam at Higher End

Cutaway foam below pans at the higher end to allow the pan turn up.

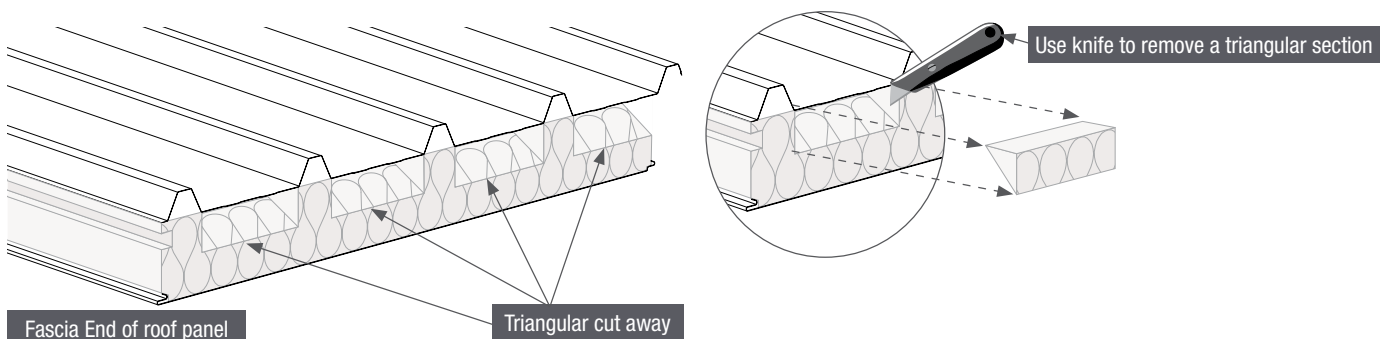

Step 4: Turn Up Pans at Higher End

SolarSpan®/InsulRoof® roofs should always have the roof pans at the higher end turned up to full rib height. It is important to ensure the pan is turned up to the full rib height for the complete width of the pan so no 'low' points exists. The Turn-up/Turn-down tool is available from your Bondor® distributor.

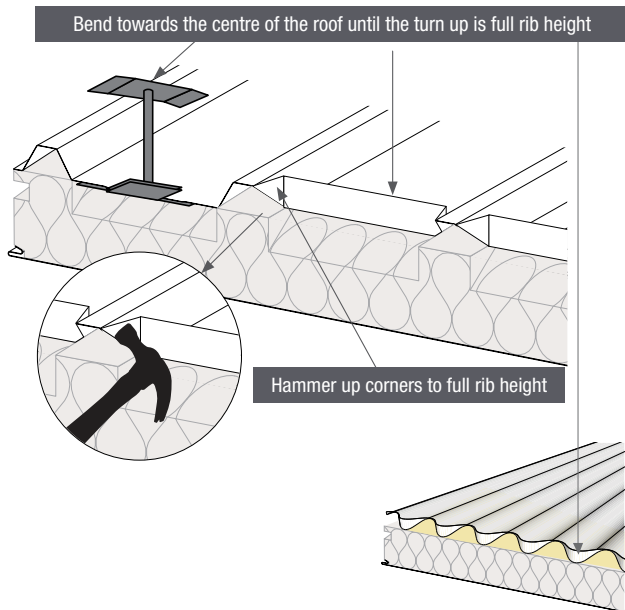

Step 5: Trim Higher End Overlap

Trim the overlay rib to prevent fouling with the turned up pan of the adjacent panel.

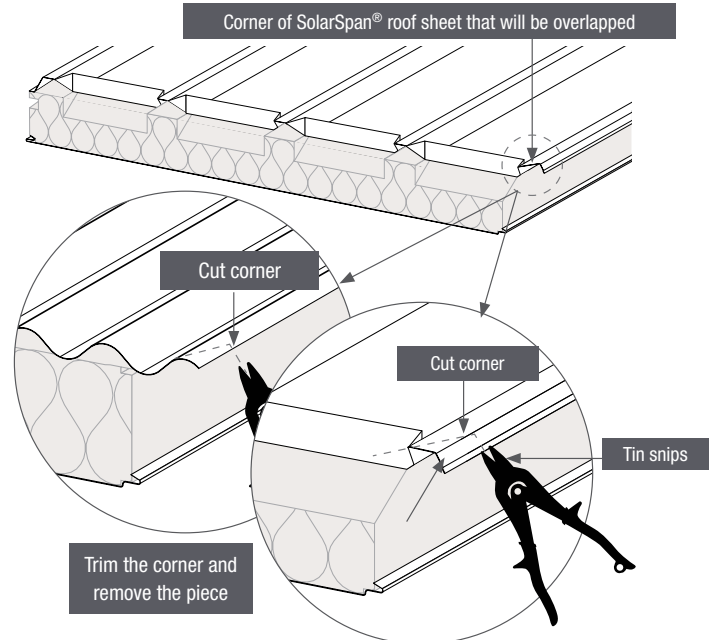

Step 6: Trim Gutter End Underlap (for SolarSpan® only)

Trim the underlay rib of every SolarSpan® panel at the gutter end to prevent water drawback via capillary action.

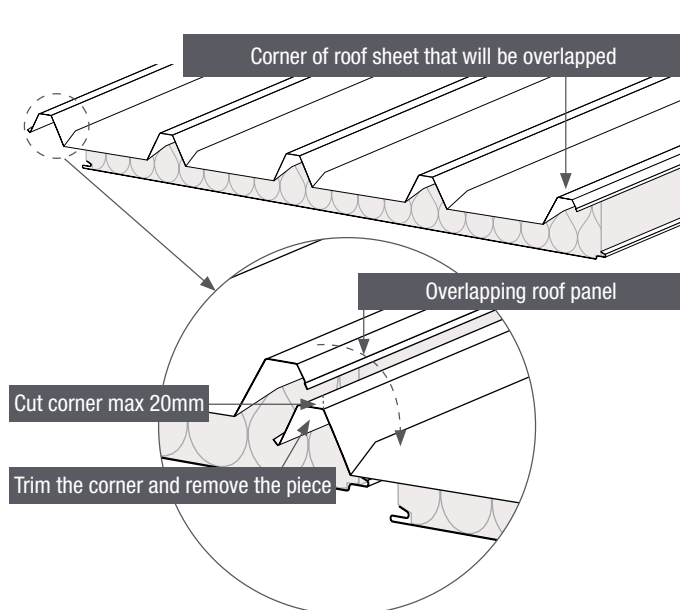

Step 7: Remove Gutter Cutback Foam

Turn the panel over roof side down on the trestles. Remove core material from the gutter cutback end of the panel with a plastic paint scraper to ensure that the fascia flashing can be installed correctly.

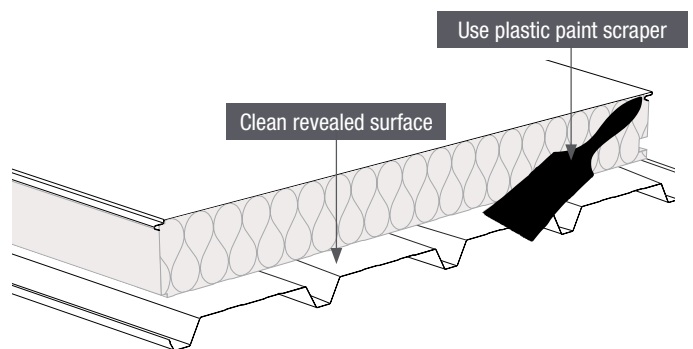

Step 8: Electrical Preparation

Mark the location of each downlight/fan, cut appropriate size hole in the SolarSpan[®]/InsulRoof[®]. Feed electrical conduit through Services Duct to fan or light location. The ceiling core-strip protective film should be left on while any marking, drilling and cutting is carried out. LED Downlights & fan bracket kits are available from your SolarSpan[®]/InsulRoof[®] installer or contact Bondor[®] for more information.

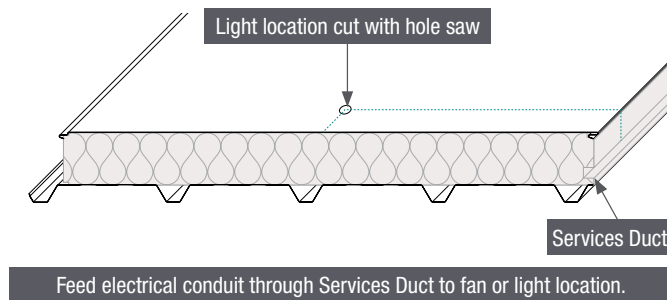

Step 9: Peel Back Plastic

Peel back protective coating on all edges of the panel ensuring you are past the beam at the front of the patio.

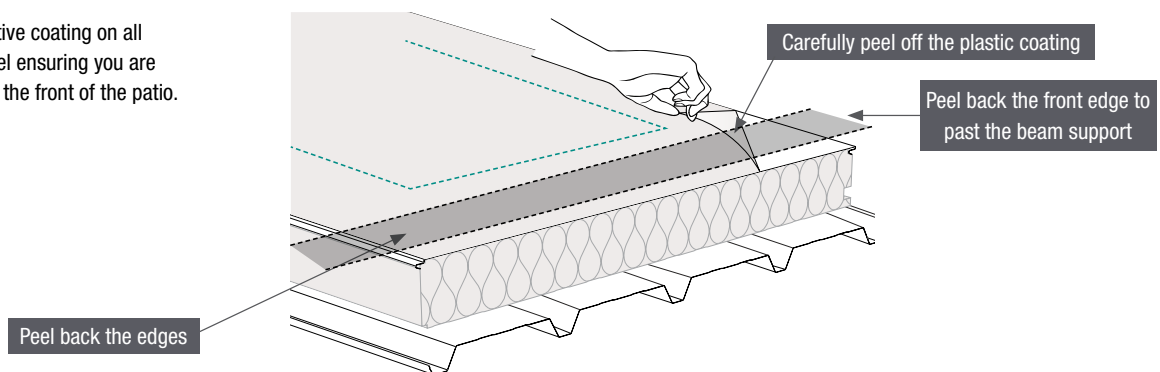

Step 10: Turn Down Pans Gutter End 20°

Turn the panel back over and use the special Turn-down tool to turn each pan of the panel approx 20° into the gutter. Turn downs should be done while safely on the ground before installing into place. Turn up/down tools are available from Bondor[®].

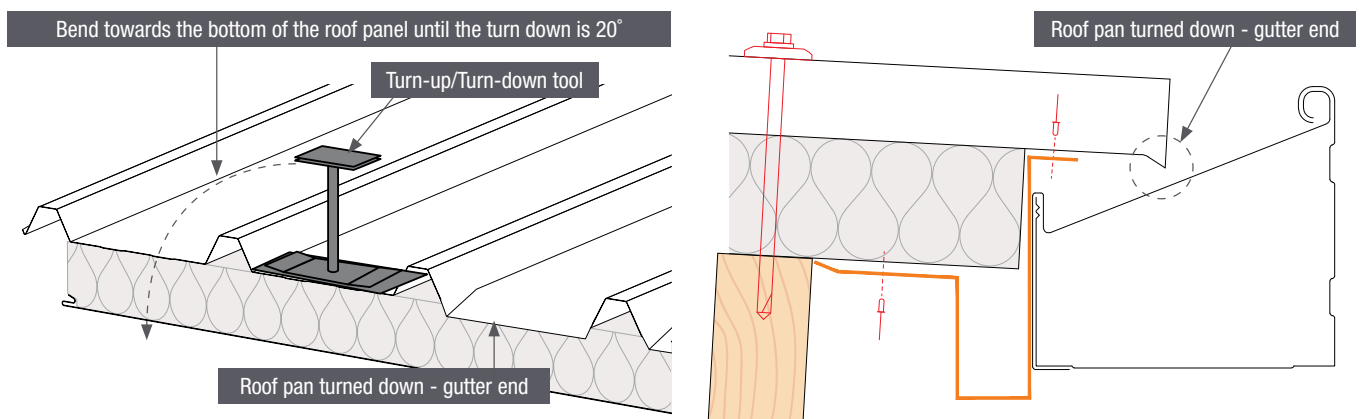

Step 11: Installing Panel

Place towel or blanket over beams to protect the first panel before sliding it into place. Place the panel on to the beams ensuring the cutback end (gutter or low end) located on the lower or downhill side of the patio. Make sure panel is located with the desired minimum side and end overhangs. See diagram on page 2.

Remove towels & protective plastic core strip. Once panel is squared up with the desired side & end overhangs it can be "pined" into place with a screw fixing in the top middle rib to hold it square and in place.

To install the second panel, place the overlay flap of the roof skin over the previously fitted panel and with the panel at approx 20° pull it down and engage the male interlock into the female interlock.

Slide this second panel to align with the first panel. To be sure you are successful, the ceiling join should be a neat 'V' join, with 0-2mm of the male interlock showing.

Screw fix to the beam ensuring your line is square.

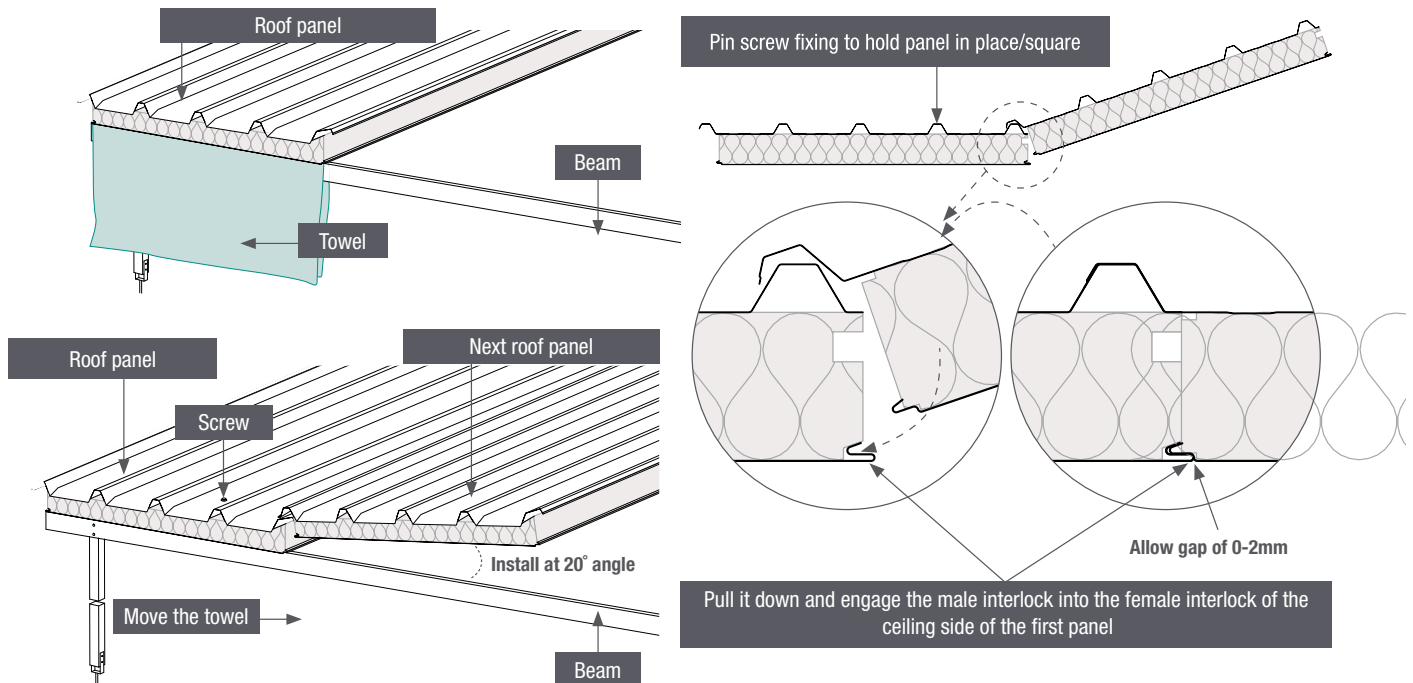

Handy Tip

Refer to SolarSpan[®] Naturelite[®] Skylight Installation Instructions if installing the skylight.

Step 12: Screw Down Remaining Ribs

Screw down the remaining ribs per fixing recommendations.

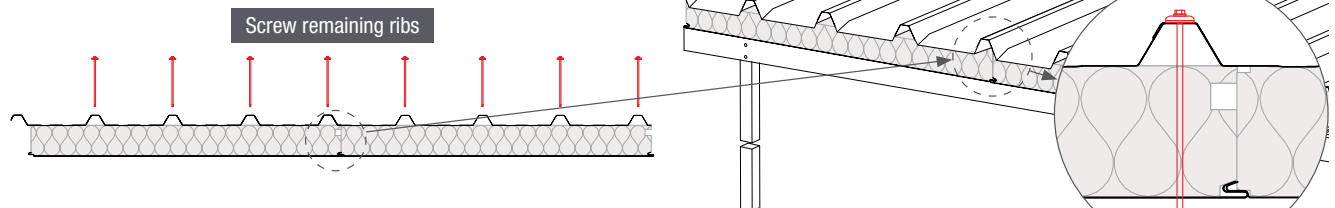

Note:

Dead loads of up to 15kg/m² are allowed.

Fixing Recommendations SolarSpan[®]

SolarSpan[®] roofing side laps should be laid away from the prevailing wind and sit neatly on the preceding roof sheet.

Non Cyclonic Fixing - Through Each Rib

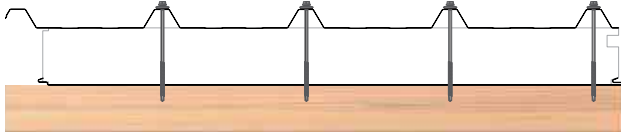

Screw with Cyclone Assembly



Lapping

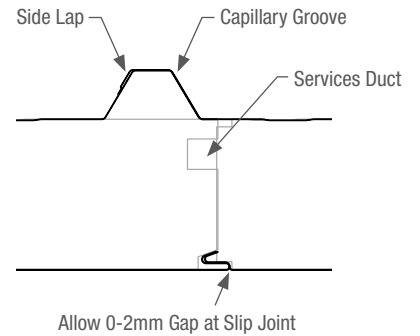

Fixing Recommendations InsulRoof[®]

4 Fixings - Minimum Through Every 3rd Crest

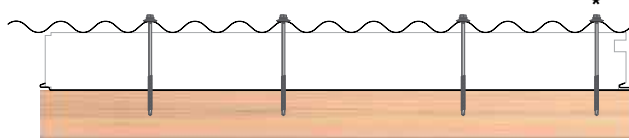

7 Fixings - Minimum Through Every 2nd Crest

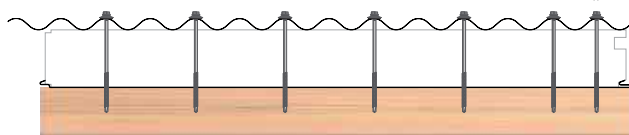

Lapping

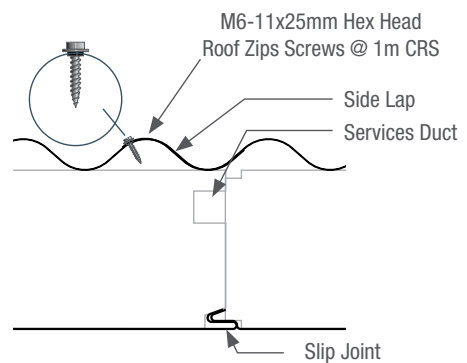

Install Barge Flashings, Fascia Flashings & Guttering

Suits 50mm			
	Fascia Gutter End Flasing	Side Barge Flasing	Top Barge Flasing
SolarSpan [®] Flashing Details			
InsulRoof [®] Flashing Details			

Install Guttering To Fascia Flashing

1. The gutters need to be cut to the exact length and if on more than one side of the verandah mitred on the corners.
2. Cut the mitres. Note the direction of water flow.
3. Fit the Stop Ends to the non-mitred ends of the gutter, sealing with silicone and riveting with pop rivets.
4. Cut a hole in the base of the gutter with the back edge lining up with the back of the gutter for the downpipe pop. Line up the hole with the column the downpipe will run down. Rivet the pop and seal with silicone.
5. Fit the suspension clips to the fascia beam with 10x16 Tek screws at 1000mm centres.
6. Lift the first length of gutter into place sliding the back of the gutter under the suspension clips. Adjust to give the gutter fall toward the downpipe position.
7. Fit the remaining side gutters riveting the mitres and sealing with silicone.
8. Fit the internal gutter straps into the bead of the gutter and fix with 10x16 screws.
9. Remove all swarf from the gutter.

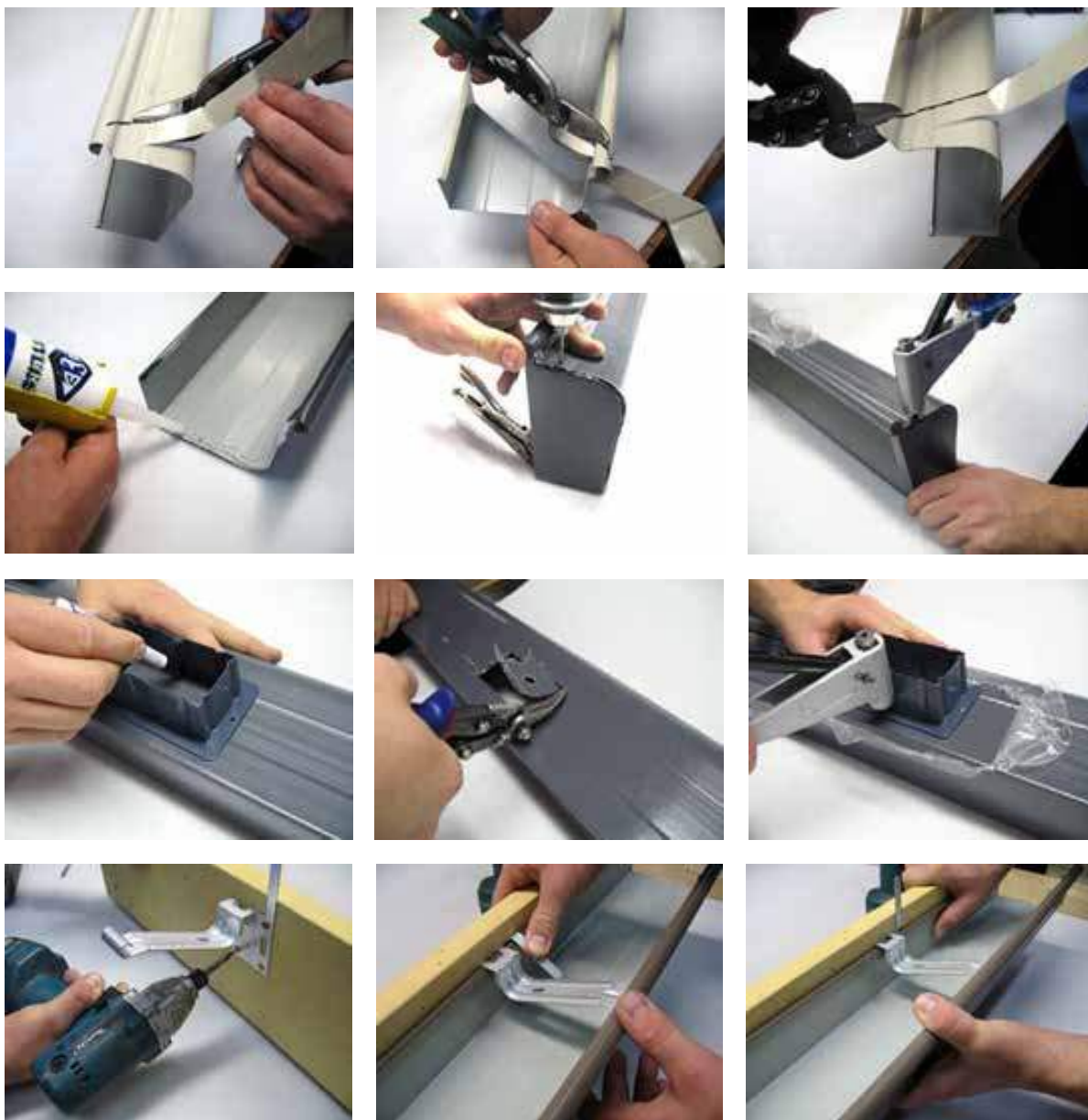

Looking After Your SolarSpan[®] / InsulRoof[®] Patio

At the Site Handling and Storage

To preserve the COLORBOND[®] surface, handling should only be carried out using clean, dry gloves. Careless handling or excessive traffic on formed panels must be avoided as it causes unsightly scuffing and marking. Do not slide sheets over rough surfaces or over each other.

Care and Storage

Care and storage of COLORBOND[®] steel prior to installation is vital to the life of the product when installed. If not required for immediate use, stack the sheets neatly and clear of the ground and provide cover to protect the sheeting from getting wet. A process called capillary action can cause corrosion which may lead to reduced life expectancy or a wet storage stain. Moisture on sheets or coil wraps of COLORBOND[®] steel can penetrate between surfaces causing temporary softening of the paint film and possibly even minor colour changes on some paint finishes. After drying, the coating will revert to its original state. Take extreme care with the surface until it has been dried and the coating hardness returns to normal.

COLORBOND[®] Steel

Rainwater goods and roof flashings should always be made from a material which is at least as durable as the roof sheeting. For example, avoid using COLORBOND[®] gutters with COLORBOND[®] ULTRA roof, or galvanised gutters with a COLORBOND[®] roof. COLORBOND[®] Ultra is ideal for severe marine and industrial environments. Both sides are treated with a high build corrosion resistant primer.

Swarf

Don't forget to clean up each day. Swarf particles and other metal scraps, such as pop rivet stems and fasteners, if left on a ZINCALUME[®]/COLORBOND[®] steel surface, will cause rust stains which will detract from the finished appearance. Swarf should be swept or hosed from the job at least at the end of each day. Maximum care should be taken when attempting to detach swarf which has become stuck; this can be done, but no action which is likely to remove the paint or metal coatings should be attempted.

Corstrip

Many COLORBOND[®] steel products are supplied with a specially designed polyethylene strippable film called CORSTRIP. This film protects the sheet during storage and handling and should be stripped off immediately on installation. Sunlight can increase the adhesion so it is vital that sheets are not left uncovered while outside.

Sealants

Neutral cure silicone rubber sealants are the only sealants recommended for use with COLORBOND[®] or ZINCALUME[®] steel. The advantages of neutral cure sealants are:

- they provide good adhesion and do not require a primer except in extreme service conditions
- they resist extremes of both heat and cold while retaining good flexibility
- they provide high resistance to the damaging effects of ultra-violet rays
- and do not have acidic additives which may adversely affect steel. This gives long life compatible with the performance of ZINCALUME[®] or COLORBOND[®] steel. Sealants should be applied to avoid exposure to UV rays (i.e. sandwiched in the lap), so they don't create water run-off and dirt tracks down a roof or facade.

Touch Up

Have you ever noticed how an otherwise professional job can be ruined by clumsy attempts to touch up minor damages such as scratches? The use of spray cans result in not only coverage of the scratch but also of a considerable area surrounding it. The problem is not immediately obvious but the overspray paint weathers at a different rate to the oven dried paint on COLORBOND[®] steel and, eventually, you will be left with an unsightly blemish on the sheet. Our recommendation is not to touch up. Minor scratching will not affect the life of the sheet and is rarely obvious to a casual observer. Should damage be substantial the sheet should be replaced. Where touch up is required for pop rivets or fastener heads, touch up lacquer is available in 250ml tins and carries clear instructions for application.

Optional Extras: Available from Your Local SolarSpan[®] / InsulRoof[®] Patio Supplier



Bolt to slab INTERNAL POST support bracket 90x90x3mm GALVANIZED



Decorative Post Skirt. 90x90 (Colour match to post)



SolarSpan[®] TURN UP TOOL



Kit Contains:

- 1 x 10W LED Downlight
- 1 x SW Driver
- 2 x DC extension lead (2m)
- 1 x 10W white (10W)
- 1 x 10W brushed chrome (optional)



Downlight kit
Cool White or Warm White

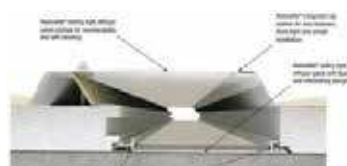

Naturelite Skylight Kit (SolarSpan[®] only) up to 5m long



Naturelite Skylight Kit (SolarSpan[®] only) up to 7.5m long



Leaders in Thermal & Architectural Building Solutions

www.bondor.com.au

1300 300 099

BRISBANE/EXPORT

103 Ingram Road Acacia Ridge QLD 4110
Ph: (07) 3323 8500 Fax: (07) 3323 8501

ADELAIDE

70-72 Rundle Road Salisbury South SA 5106
Ph: (08) 8282 5000 Fax: (08) 8282 5099

LAUNCESTON

7 Connector Park Drive Kings Meadows TAS 7249
Ph: (03) 6335 8500 Fax: (03) 6335 8544

PERTH

17 Gauge Circuit Canning Vale WA 6155
Ph: (08) 9256 0600 Fax: (08) 9256 0620

MELBOURNE

6 Dunmore Drive, Truganina VIC 3029
Ph: (03) 8326 8000 Fax: (03) 8326 8099

SYDNEY

49-53 Newton Road Wetherill Park NSW 2164
Ph: (02) 9609 0888 Fax: (02) 9729 1114